



▶ Remote Reading Telltale System



Dual height remote reading telltale

System Overview

Roof control telltales have become established worldwide as a highly effective means of identifying and measuring roof movement in underground excavations, providing a major contribution to mine safety. Golder RMT Telltales are simple but effective wire extensometers anchored in a small diameter borehole, which give a visual warning of rock deformation through movement of an indicator.

The Mark III visual dual height telltale, developed by Golder RMT in the UK over the last ten years, has become the industry standard. The great advantage of the system is that the dual height feature allows movement above and below the rockbolted horizon to be distinguished at a glance. This provides underground workers with instant information on roof condition and operational management with excellent warning of remedial action requirements and roof deformation history. In many countries around the world our Telltales are installed and read on a routine basis to provide a reliable roof control management system. The system is patented in the UK, USA, Australia, China, Poland, and Canada.

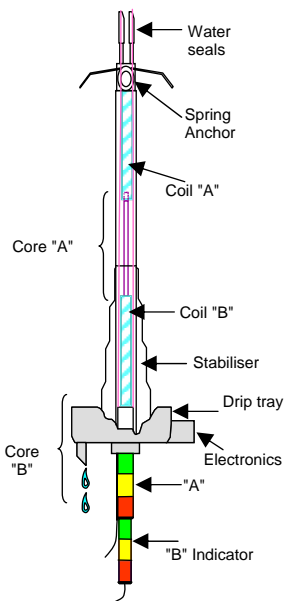

Remote reading telltale transponder

With the new Remote Reading Telltale System, we have taken the telltale concept to the next level. Up to 400 telltales can now be integrated at low cost into a mine wide monitoring system to provide instant, highly accurate data on roof condition on a surface PC. The system allows up to 100 dual height telltales to be strung together along each of 4 separate tunnels in a simple "daisy chain" configuration using just a twin core connection cable. As each tunnel excavation advances, new transponders can be added, with the trailing cable crimped to the leading cable from the last telltale. At the other end of each chain of transponders the cable is connected to an underground interrogation and communications unit. This sends data to the surface PC, using a twisted wire pair, and provides local interrogation and diagnostic facilities. Up to 4 units can be connected to a single PC. The PC can, in turn, be remotely monitored and controlled with a suitable software package.

The surface PC software has been written to provide a simple user friendly interface. The standard display provides information on the current reading and recent history of all the connected telltales. Individual warning and action levels can be set for each telltale, both as absolute levels or rates of change. The software provides an archiving facility to allow a subset of the data to be stored for later access via our standard telltale for windows program. It also provides automatic recognition of new telltales as and when they are added to the system.

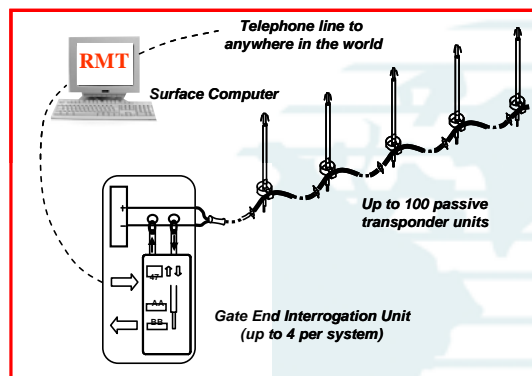

RMT011-S/07-09 V2

Golder Associates (UK) Ltd
 Trading as Golder RMT
 A world of capabilities delivered locally

www.rmtltd.com
www.golder.com



Remote Reading Telltales

View Help

New Instruments: No new instruments Inactive Channels: Inactive instruments on system 1

Warnings/Messages:

Telltale Readings

Gates: MMark	23/01/2002				24/01/2002				Current Rdgs(mm), R.O.M(mm/h)				Action Level Status			
	A Rdg	B Rdg	Total	R.O.M	A Rdg	B Rdg	Total	R.O.M	A Rdg	B Rdg	Total	R.O.M	A	B	Total	R.O.M
1830 @ 124MM	0.5	0.0	0.5	0.1	0.0	0.0	0.0	0.0	0.4	0.0	0.4	0.0	Ok	Ok	Ok	Ok
1830 @ 141MM	0.0	0.0	0.0	0.0	0.0	0.0	0.0	0.0	0.0	0.0	0.0	0.0	Ok	Ok	Ok	Ok
1830 @ 155MM	0.0	1.4	1.4	0.0	0.0	1.4	1.4	0.0	0.0	1.3	1.3	0.0	Ok	Ok	Ok	Ok
1830 @ 161MM	0.0	0.0	0.0	0.0	0.0	0.0	0.0	0.0	0.0	0.0	0.0	0.0	Ok	Ok	Ok	Ok
1830 @ 181MM	0.0	0.0	0.0	0.0	0.0	0.0	0.0	0.0	0.0	0.0	0.0	0.0	Ok	Ok	Ok	Ok
1830 @ 204MM	3.7	0.5	4.1	0.0	3.0	0.6	4.4	0.0	3.4	0.5	3.9	0.0	Ok	Ok	Ok	Ok
1830 @ 226MM	0.0	0.7	0.7	0.0	0.0	0.0	0.0	0.0	0.0	0.7	0.7	0.0	Ok	Ok	Ok	Ok
1830 @ 244MM	1.1	1.1	2.2	0.0	1.1	1.1	2.2	0.0	1.1	1.0	2.0	0.0	Ok	Ok	Ok	Ok
1830 @ 256MM	0.9	0.0	1.0	0.0	0.0	0.0	0.0	0.0	0.5	0.0	0.5	0.0	Ok	Ok	Ok	Ok
1830 @ 264MM	2.9	0.2	3.1	0.0	2.8	0.3	3.2	0.0	3.0	0.3	3.3	0.0	Ok	Ok	Ok	Ok
1830 @ 266MM	0.0	0.0	0.0	0.0	0.0	0.0	0.0	0.0	0.0	0.0	0.0	0.0	Ok	Ok	Ok	Ok
1830 @ 304MM	0.4	0.2	0.6	0.0	0.4	0.2	0.5	0.0	0.4	0.2	0.6	0.0	Ok	Ok	Ok	Ok
1830 @ 324MM	0.1	0.0	0.1	0.0	0.1	0.0	0.1	0.0	0.1	0.0	0.1	0.0	Ok	Ok	Ok	Ok
1830 @ 344MM	0.0	0.0	0.0	0.0	0.0	0.0	0.0	0.0	0.0	0.0	0.0	0.0	Ok	Ok	Ok	Ok
1830 @ 362MM	3.1	0.0	3.1	0.0	3.1	0.0	3.1	0.0	3.2	0.0	3.2	0.0	Ok	Ok	Ok	Ok
1830 @ 375MM	0.0	0.1	0.1	0.0	0.0	0.1	0.1	0.0	0.0	0.0	0.0	0.0	Ok	Ok	Ok	Ok
1830 @ 382MM	0.0	0.3	0.3	0.0	0.0	0.4	0.4	0.0	0.0	0.3	0.3	0.0	Ok	Ok	Ok	Ok
1830 @ 400MM	0.0	0.1	0.1	0.0	0.0	0.2	0.2	0.0	0.0	0.2	0.2	0.0	Ok	Ok	Ok	Ok
1830 @ 422MM	0.1	0.0	0.1	0.0	0.4	0.4	0.7	0.0	0.3	0.3	0.6	0.0	Ok	Ok	Ok	Ok
1830 @ 445MM	0.0	0.6	0.6	0.0	0.0	0.6	0.6	0.0	0.0	0.6	0.6	0.0	Ok	Ok	Ok	Ok
1830 @ 465MM	0.0	0.2	0.2	0.0	0.1	0.3	0.3	0.0	0.0	0.3	0.3	0.0	Ok	Ok	Ok	Ok
1830 @ 484MM	1.3	0.2	1.4	0.0	1.3	0.1	1.5	0.0	1.3	0.1	1.5	0.0	Ok	Ok	Ok	Ok
1830 @ 496MM	0.0	0.2	0.2	0.0	0.0	0.3	0.3	0.0	0.0	0.3	0.3	0.0	Ok	Ok	Ok	Ok
1830 @ 516MM	0.5	0.0	0.5	0.0	0.5	0.0	0.5	0.0	0.5	0.0	0.5	0.0	Ok	Ok	Ok	Ok
1830 @ 538MM	0.0	0.0	0.0	0.0	0.0	0.0	0.0	0.0	0.0	0.0	0.0	0.0	Ok	Ok	Ok	Ok
1830 @ 549MM	0.0	0.0	0.0	0.0	0.0	0.0	0.0	0.0	0.0	0.0	0.0	0.0	Ok	Ok	Ok	Ok
1830 @ 561MM	0.0	0.9	0.9	0.0	0.0	0.9	0.9	0.0	0.0	0.9	0.9	0.0	Ok	Ok	Ok	Ok

25/01/2002 11:39:09 Interval = 20 Slots per day = 72 Active Instruments = 51 No New Inst's on System Current User: SuperUser

Example of surface PC display

Communications Principles

The system has been designed with reliability and fault tolerance as the core requirements. A highly reliable frequency based method is used by the local communications unit to address and interrogate each transponder in turn. This overcomes the danger of sensitivity to poor connections in the harsh underground environment. The transponders can be installed and connected up by the mining workforce using a simple crimp connection without the need for specialist engineers.

Each transponder is supplied with a unique pre-programmed address, from 1 to 120, and can be connected in any order. The 20 additional addresses are provided to allow any units which develop faults to be replaced by a spare without the need to use the same address for the replacement.

This greatly reduces stock holding requirements. The surface computer software is designed to automatically detect when old transponders are removed and when new transponders are fitted and to determine their location and function through a simple question and answer session with the surface operator. Transponder scanning rate is user selectable with a maximum rate of one every 20 seconds.

The Transponder

The basic mechanical operation and method of installation of the remote reading telltale transponder is identical to the visual Mark III dual height telltale. Two concentric indicator cylinders are attached via stainless steel wires to anchor springs installed at different heights in a 35mm borehole.

The top indicator cylinder (A) is attached to the lower spring which is anchored in the borehole just below the top of the rockbolts. The lower indicator (B) is attached to the upper spring anchored at a stable height, usually at least twice the bolted height. Movement within the rockbolted height is registered on the A cylinder which is read visually relative to the plastic reference tube. Movement above the rockbolts (and below the upper anchor) is registered on the B indicator which is read relative to the bottom of the A cylinder.

Each indicator cylinder is marked with 3 different coloured bands at 25mm increments, plus a millimetre scale. The coloured bands allow instant recognition by all who pass of the magnitude of movement. If the green band can be seen, less than 25mm of movement has occurred. If the yellow band can be seen but not the green band, between 25mm and 50mm of movement has occurred. If only the red band is visible, more than 50mm of movement has occurred. The millimetre scale allows accurate reading of each indicator.





In addition to the visual indications of movement described above, the remote reading telltale transponder measures the displacements of the two indicator cylinders electronically. It uses the principle of changing inductance of a coil as a ferrite rod moves through it. This measurement method has the advantage of not moving contacts. It avoids the measurement of electrical resistance used by most low cost position measuring devices which can be prone to serious problems in the demanding mining environment.

The onboard transponder electronics include an address recognition system and a measurement circuit which converts the measured inductance to a frequency for detection by the underground interrogation unit. Accuracy is better than 0.5mm. The circuit is designed to be intrinsically safe and to have extremely low power consumption. In the dormant mode power consumption per transponder is only 0.6 milliamps. This means that all power can be supplied from a single 12v power supply connected to the underground interrogation unit. The transponders do not use on-board batteries of any kind and so are maintenance free.

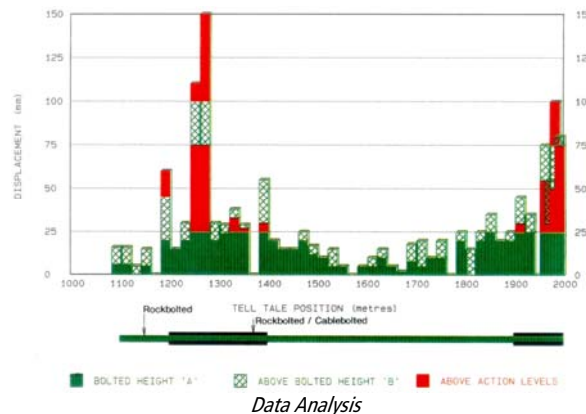

The graph shown above is a typical graph plotted by the Telltale for Windows software package representing the current condition of telltales at 20m spacing along a coal mine tunnel. It shows where action levels have been exceeded within the bolted height and above the top of the roof bolts and also what, if any, remedial action has been taken. The Remote Reading Telltale System allows such graphs to be plotted easily on demand without the need for manual underground reading of the telltales.

Intrinsic Safety

The system has full European and US Intrinsic Safety Approval for class 1 atmospheres.

European Certificates of Conformity to:

- ▶ MECS 02 ATEX 7013 for the Surface Communications Interface
- ▶ MECS 02 ATEX 4014 for the Remote Reading Telltale System
- ▶ MECS No. 99E7258 Remote Reading Telltale (overall) system

American Mine Safety and Health Administration (MSHA) authority approval No. 2G-4098-0.

For further information please contact:

David Bigby
 Technical Director Instrumentation
 Tel: +44 (0)1283 522201
 Email: dbigby@golder.com



Golder Associates

